

Product Line

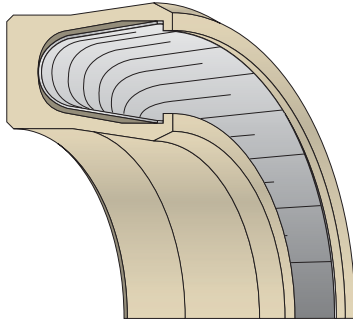

FlexiSeal

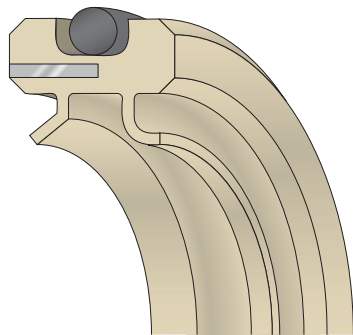

FlexiLip

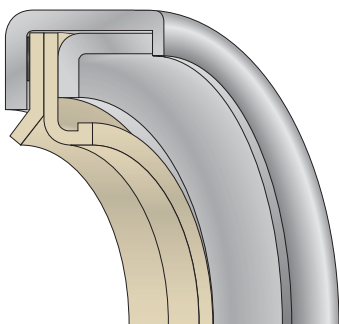

FlexiCase

PTFE FlexiSeal®

The FlexiSeal is a spring-energized U-cup utilizing a variety of jacket profiles, spring types and materials in Rod & Piston, Face and Rotary seal configurations. FlexiSeals are used where elastomeric seals fail to meet the temperature range, chemical resistance or friction requirements. Jacket profiles are made from PTFE and other high performance polymers. Spring types are available in corrosion-resistant metal alloys, including stainless steel, Elgiloy® and C-276 alloy. Standard FlexiSeals are precision machined to fit inch/fractional and MIL-G-5514 glands. Standard and custom sizes in multiple geometries are available from 1/8" to 72" diameters.

FlexiLip™

FlexiLip seals are rotary seals incorporating a deflected lip seal geometry. Anti-rotational devices such as flanges and O-rings are often utilized to prevent the seal from rotating with the shaft. Standard and custom sizes are available with a wide selection of PTFE materials. FlexiLip seals are suitable for sealing corrosive and abrasive media. A wide range of geometries and materials are available, depending on specific application requirements. FlexiLip seals are often used when quantities are small (<100pc/yr) and it is difficult to justify tooling costs for a FlexiCase solution.

FlexiCase™

The FlexiCase seal is a metal-cased rotary lip seal suitable for applications where elastomeric lip seals fail and mechanical seals are too costly. The filled PTFE element provides greater chemical compatibility, wider temperature ranges, higher pressure capabilities, and longer life than elastomeric lip seals. FlexiCase seals:

- Can run in dry and abrasive media environments
- Are available in single, dual and triple lip designs
- Are designed to press fit into a counterbore



Master Decision Tree

Don't know which of the 66 standard profiles best fits your application? Just start at the left and begin answering the basic application questions in the decision tree. Follow the tree through, and it will guide you to the profile that should be the best fit for your application.

The decision trees in this guide are to be used as an engineering guide only. Often several other parameters must be considered to optimize seal design. Contact Parker's PTFE Engineering Team for confirmation of your choice or further recommendations. Parker also recommends that any seal be tested in the application conditions before releasing for production.

4

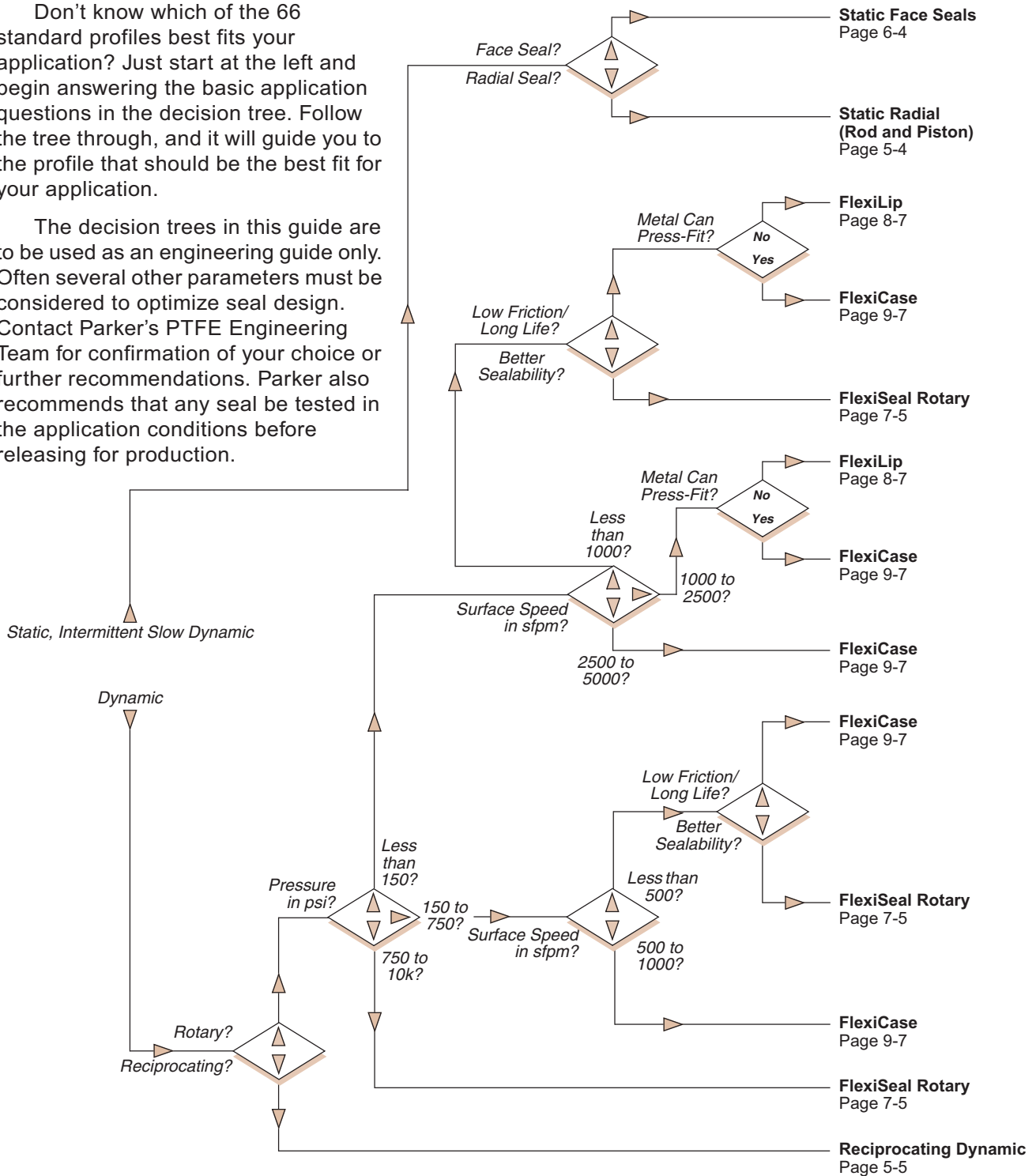

01/15/06



Part Number Nomenclature — FlexiSeal

Table 4-1. FlexiSeal Part Number Nomenclature

English

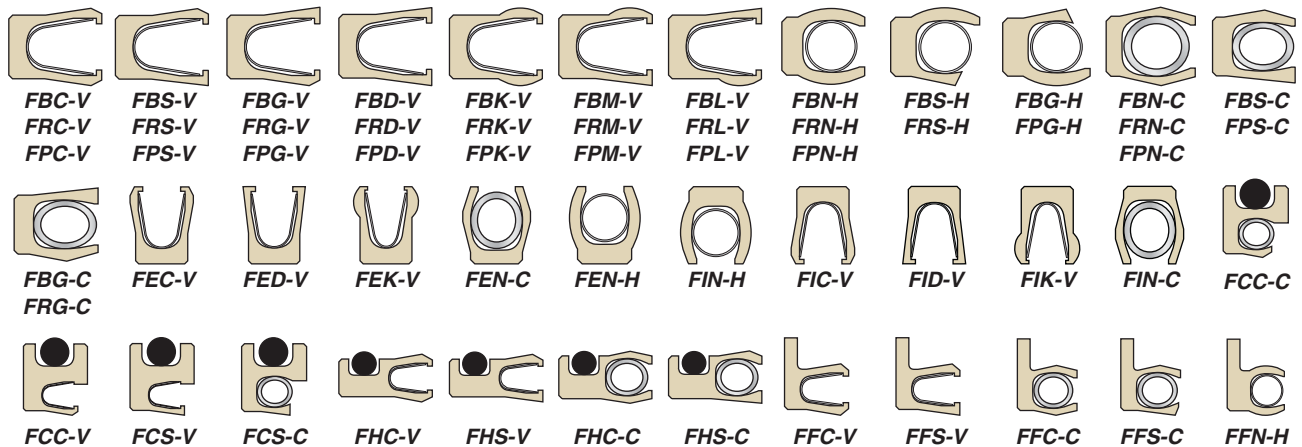
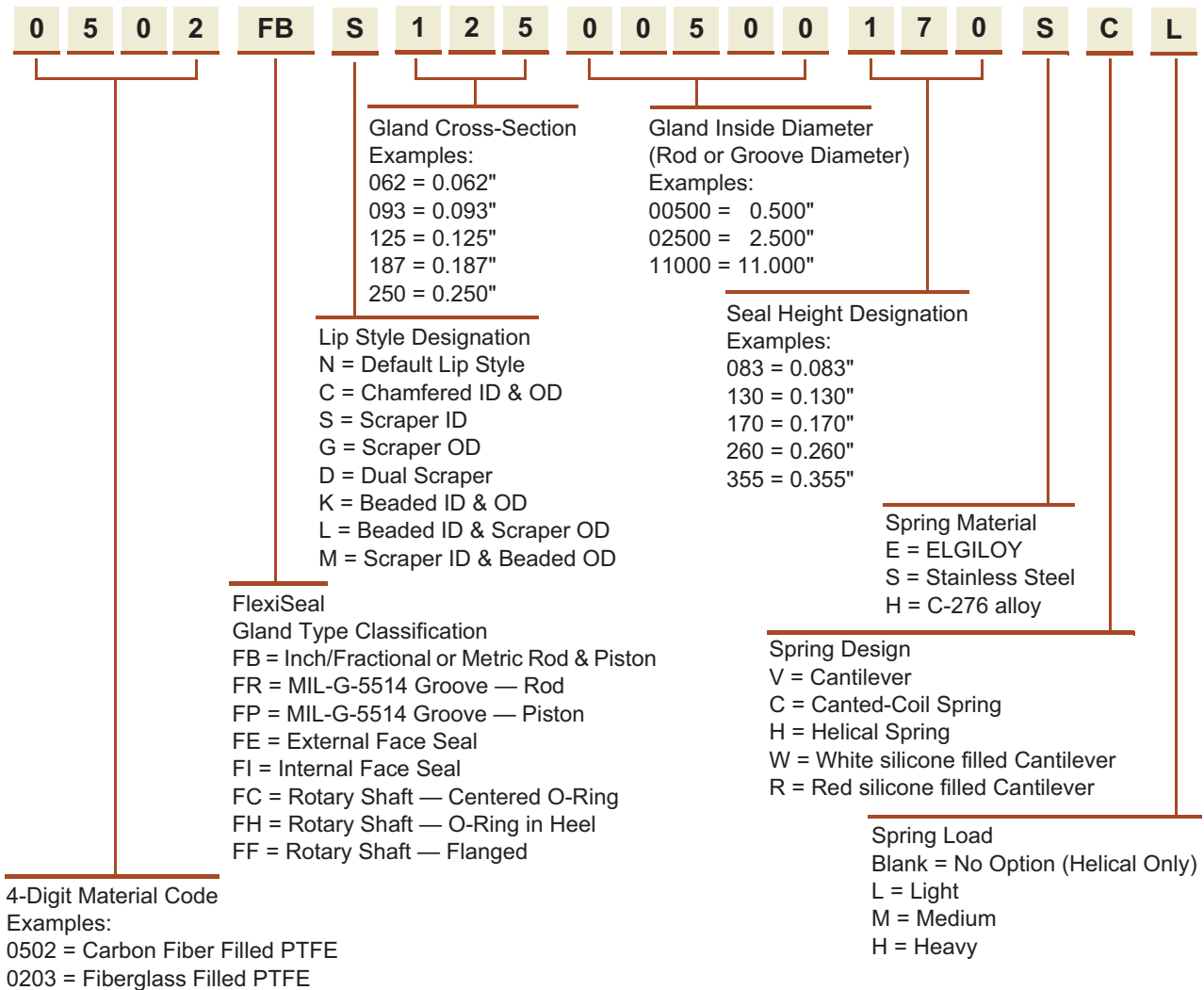

02/15/08



Product Offering

Table 4-1. FlexiSeal Part Number Nomenclature (Continued)

Metric

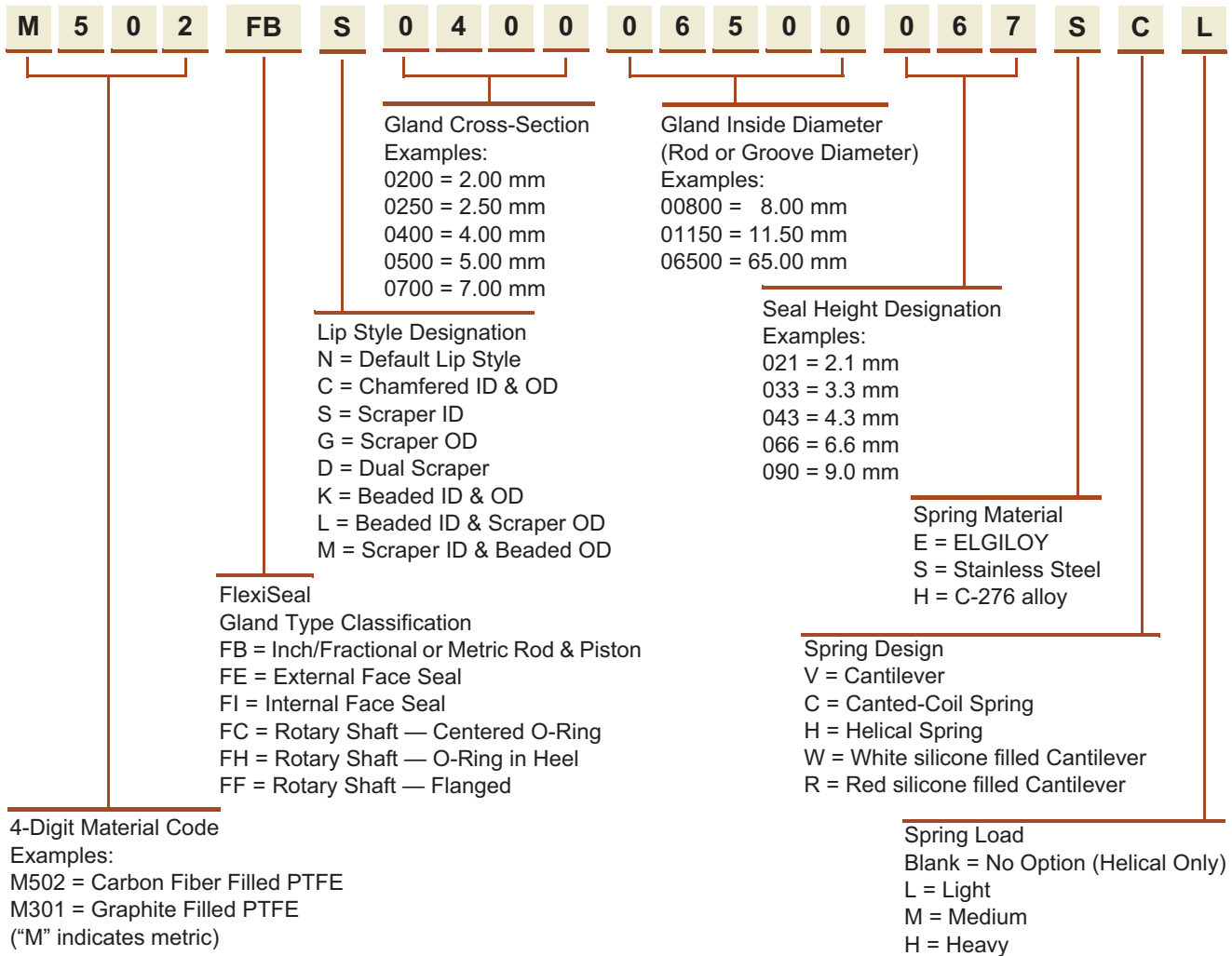

4

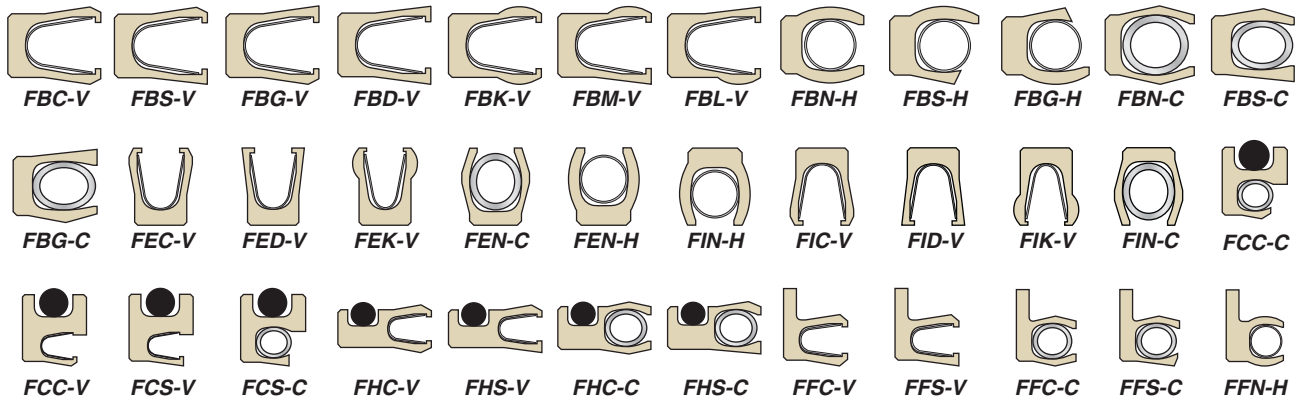

02/15/08



Part Number Nomenclature — FlexiLip

Table 4-2. FlexiLip Part Number Nomenclature

English

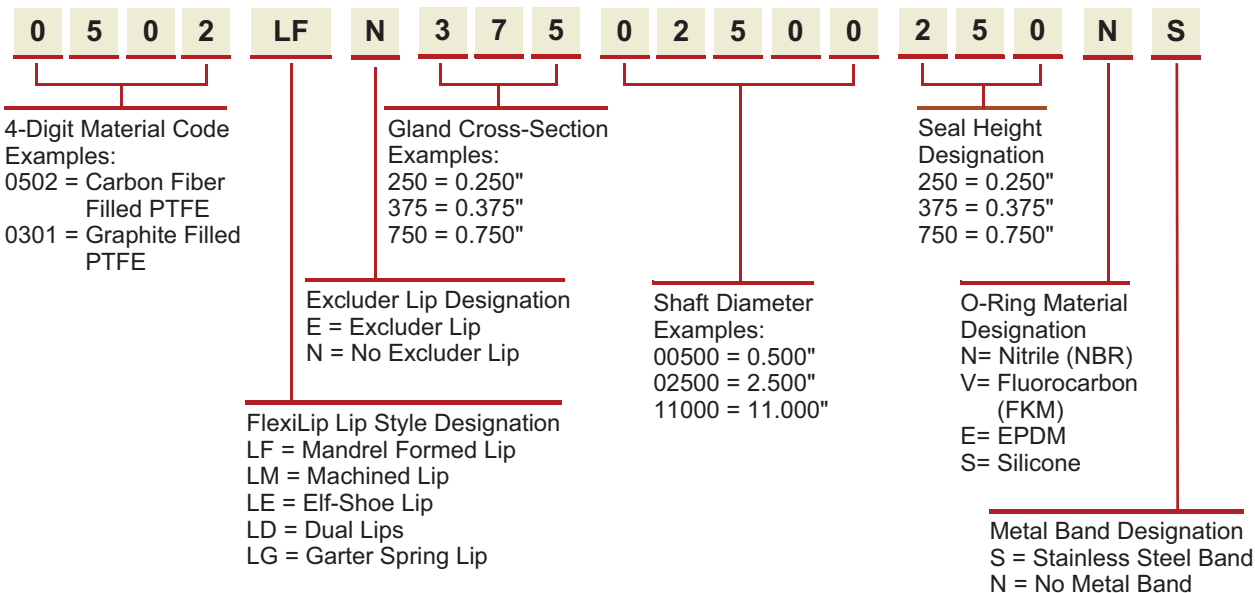

Metric

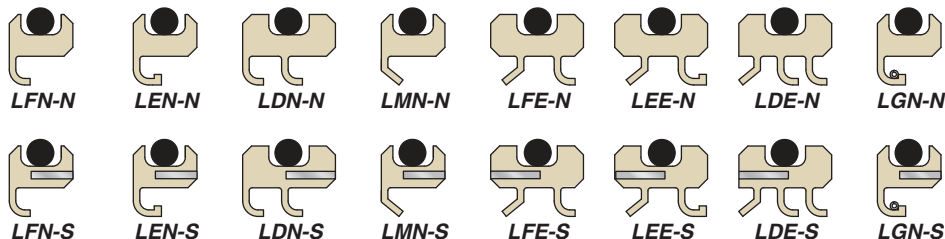
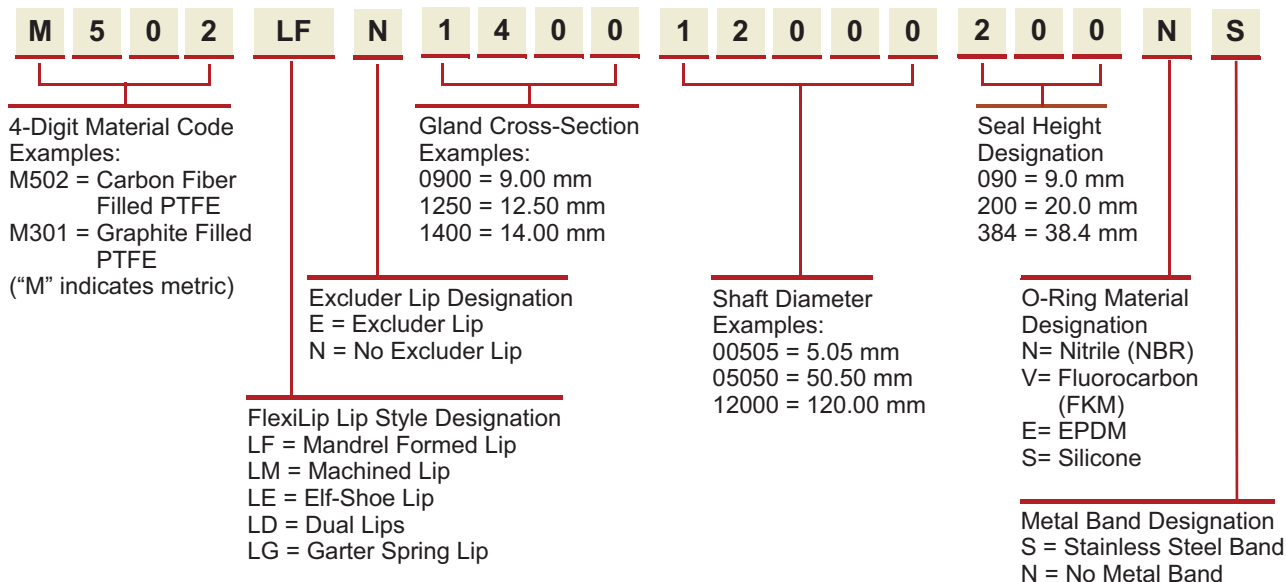

01/15/06



Part Number Nomenclature — FlexiCase

Table 4-3. FlexiCase Part Number Nomenclature

English

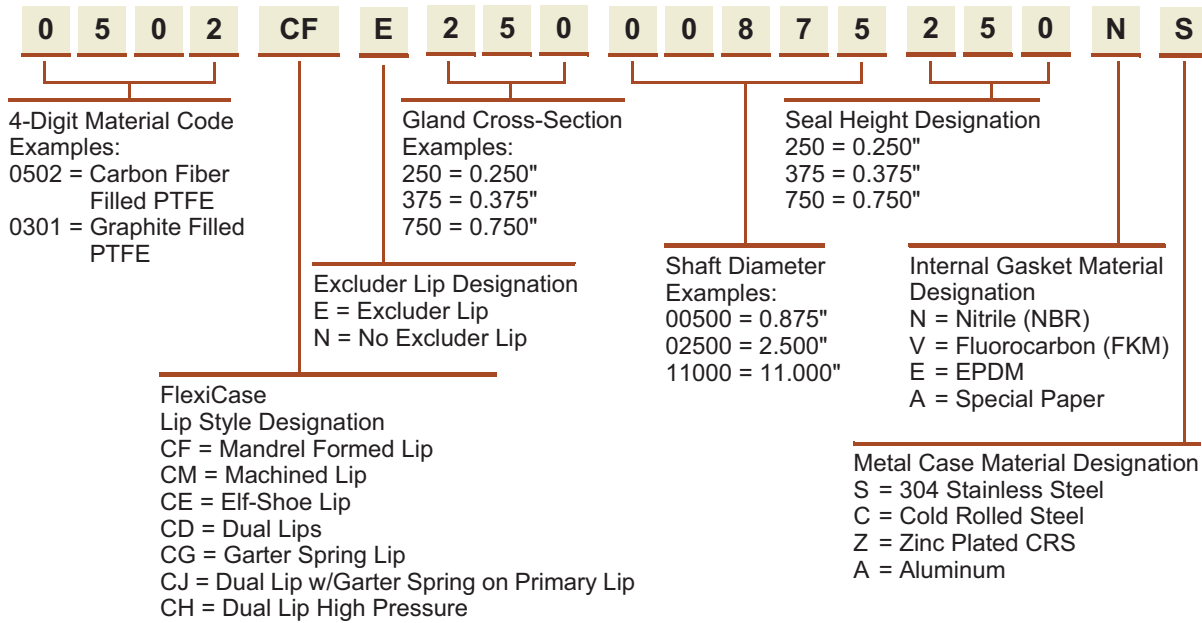



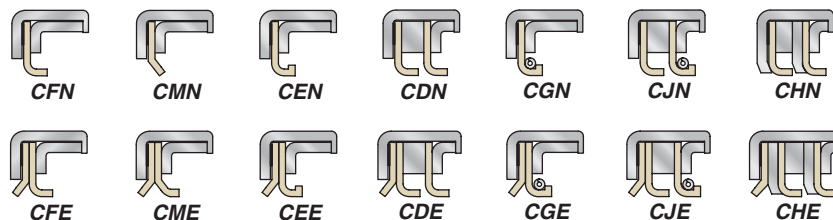
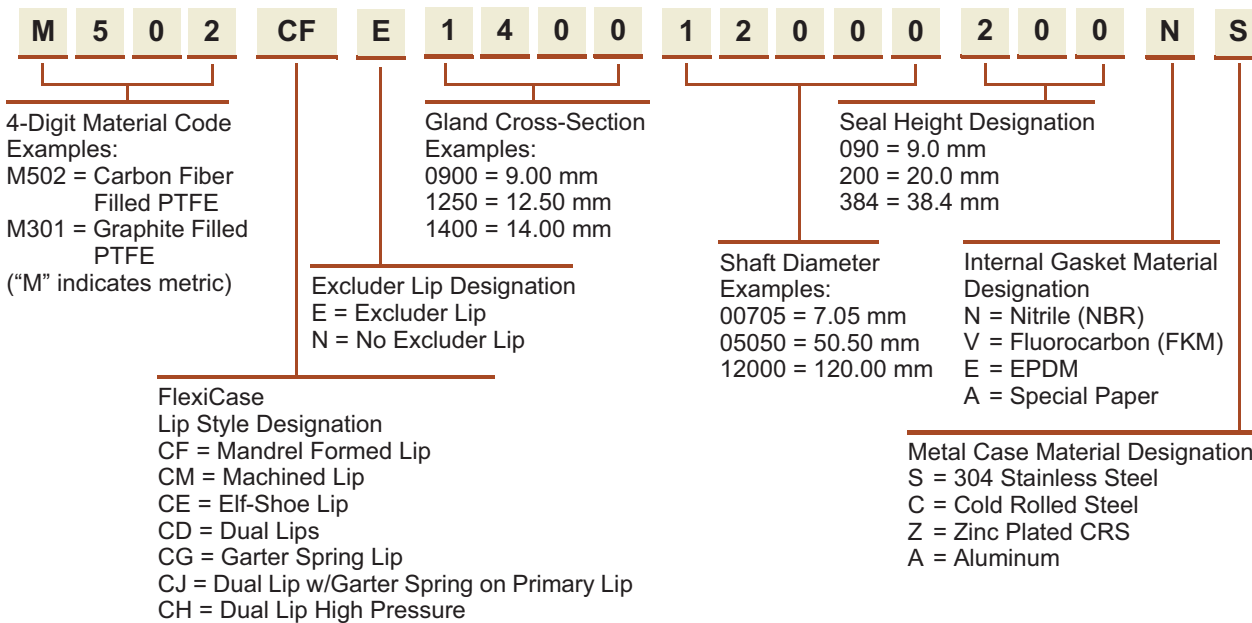









Metric



01/15/06

Profiles

Table 4-4. FlexiSeal Rod & Piston Product Profiles

Profile	Features	Recommended Applications	Profile	Features	Recommended Applications
FBC-V, FPC-V, FRC-V 	Chamfered ID & OD, Cantilever Spring	Maximum sealability on ID & OD.	FBN-H, FPN-H, FRN-H 	Rounded ID & OD, Helical Spring	High radial load increases sealability and friction.
FBS-V, FPS-V, FRS-V 	Scraper ID, Chamfered OD, Cantilever Spring	Scrapes contamination from rod surface.	FBS-H, FRS-H 	Scraper ID, Rounded OD, Helical Spring	Scrapes contamination from rod surface.
FBG-V, FPG-V, FRG-V 	Scraper OD, Chamfered ID, Cantilever Spring	Scrapes contamination from bore surface.	FBG-H, FPG-H 	Scraper OD, Rounded ID, Helical Spring	Scrapes contamination from bore surface.
FBD-V, FPD-V, FRD-V 	Scraper ID & OD, Cantilever Spring	Best overall in contaminated media.	FBN-C, FPN-C, FRN-C 	Back-beveled ID & OD, Canted-Coil Spring	Low radial load decreases friction and sealability.
FBK-V, FPK-V, FRK-V 	Beaded ID & OD, Cantilever Spring	Beaded lip similar to O-ring contact area.	FBS-C, FPS-C 	Scraper ID, Chamfered OD, Canted-Coil Spring	Easily snaps into a stepped gland for a piston seal.
FBM-V, FPM-V, FRM-V 	Scraper ID, Beaded OD, Cantilever Spring	Scrapes contamination from rod surface.	FBG-C, FRG-C 	Scraper OD, Chamfered ID, Canted-Coil Spring	Easily snaps into a stepped gland for a rod seal.
FBL-V, FPL-V, FRL-V 	Scraper OD, Beaded ID, Cantilever Spring	Scrapes contamination from bore surface.			

See a more detailed product offering for FlexiSeal Rod & Piston Seals on **Page 5-8**.

FlexiSeal Rod & Piston Seals Part Number Example





0 5 0 2 **FB C** 1 2 5 0 0 5 0 0 1 6 0 S **V** **M**



02/15/08

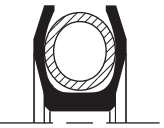

Product Offering

Table 4-5. FlexiSeal Face Product Profiles

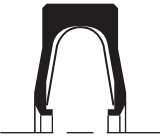
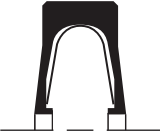
Profile	Features	Recommended Applications
FEN-H 	Lips Facing Out, Rounded Lips, Helical Spring	Seals external pressure. High sealability and closure force.
FEC-V 	Lips Facing Out, Chamfered Lips, Cantilever Spring	Seals external pressure. Good sealability for non-abrasive fluids.
FED-V 	Lips Facing Out, Scraper Lips, Cantilever Spring	Seals external pressure. Good sealability for abrasive fluids.
FEK-V 	Lips Facing Out, Beaded Lips, Cantilever Spring	Seals external pressure. Good sealability for non-abrasive fluids. Rounded like O-ring.
FEN-C 	Lips Facing Out, Back-Beveled Lips, Canted-Coil Spring	Seals external pressure. Low closure force for non-abrasive fluids.

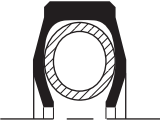
Profile	Features	Recommended Applications
FIN-H 	Lips Facing In, Rounded Lips, Helical Spring	Seals internal pressure. High sealability and closure force.
FIC-V 	Lips Facing In, Chamfered Lips, Cantilever Spring	Seals internal pressure. Good sealability for non-abrasive fluids.
FID-V 	Lips Facing In, Scraper Lips, Cantilever Spring	Seals internal pressure. Good sealability for abrasive fluids.
FIK-V 	Lips Facing In, Beaded Lips, Cantilever Spring	Seals internal pressure. Good sealability for non-abrasive fluids. Rounded like O-ring.
FIN-C 	Lips Facing In, Back-Beveled Lips, Canted-Coil Spring	Seals internal pressure. Low closure force for non-abrasive fluids.

See a more detailed product offering for FlexiSeal Face Seals on **Page 6-6**.

FlexiSeal Face Seals Part Number Example

0 3 0 1 **FE** **N** 1 2 5 0 1 2 5 0 1 6 0 S **H**

01/15/06



Table 4-6. FlexiSeal Rotary Product Profiles

Profile	Features	Recommended Applications	Profile	Features	Recommended Applications
FCC-V 	O-Ring Centered in OD, Chamfered ID, Cantilever Spring	Optimum sealability. Available in 0.125" cross-section and higher.	FHC-C 	O-Ring in Heel OD, Chamfered ID, Canted-Coil Spring	Reduced friction and sealability. Available in extended heel option only.
FCS-V 	O-Ring Centered in OD, Scraper ID, Cantilever Spring	Minimizes contamination threat. Available in 0.125" cross-section and higher.	FHS-C 	O-Ring in Heel OD, Scraper ID, Canted-Coil Spring	Low friction with contamination resistance. Available in extended heel option only.
FCC-C 	O-Ring Centered in OD, Chamfered ID, Canted-Coil Spring	Reduced friction and sealability. Available in 0.125" cross-section and higher.	FFC-V 	Flanged Heel OD, Chamfered ID, Cantilever Spring	Optimum sealability. Premium bore retention.
FCS-C 	O-Ring Centered in OD, Scraper ID, Canted-Coil Spring	Low friction with contamination resistance. Available in 0.125" cross-section and higher.	FFS-V 	Flanged Heel OD, Scraper ID, Cantilever Spring	Minimizes contamination threat. Premium bore retention.
FHC-V 	O-Ring in Heel OD, Chamfered ID, Cantilever Spring	Optimum sealability. Available in extended heel option only.	FFC-C 	Flanged Heel OD, Chamfered ID, Canted-Coil Spring	Reduced friction and sealability. Premium bore retention.
FHS-V 	O-Ring in Heel OD, Scraper ID, Cantilever Spring	Minimizes contamination threat. Available in extended heel option only.	FFS-C 	Flanged Heel OD, Scraper ID, Canted-Coil Spring	Low friction with contamination resistance. Premium bore retention.
			FFN-H 	Flanged Heel OD, Rounded ID, Helical Spring	Static or intermittent rotary only. High sealability and friction.

See a more detailed product offering for FlexiSeal Rotary Seals on **Page 7-7**.

FlexiSeal Rotary Seals Part Number Example

0 5 0 2 **FC** **C** 1 2 5 0 0 5 0 0 1 6 0 S **V** **M**



Table 4-7. FlexiLip Product Profiles

Profile	Features	Recommended Applications	Profile	Features	Recommended Applications
LFN-N 	Formed Primary Lip	Multipurpose Seal	LFN-S 	Formed Primary Lip w/ Metal Band	Multipurpose Seal
LFE-N 	Formed Primary Lip w/ Excluder Lip	Multipurpose Seal	LFE-S 	Formed Primary Lip w/ Excluder Lip w/ Metal Band	Multipurpose Seal
LMN-N 	Machined Primary Lip	Low Friction	LMN-S 	Machined Primary Lip w/ Metal Band	Low Friction
LEN-N 	Elf-Toe Primary Lip	Abrasive Media	LEN-S 	Elf-Toe Primary Lip w/ Metal Band	Abrasive Media
LEE-N 	Elf-Toe Primary Lip w/ Excluder Lip	Abrasive Media	LEE-S 	Elf-Toe Primary Lip w/ Excluder Lip w/ Metal Band	Abrasive Media
LDN-N 	Dual Primary Lips	Oil Seal — Flooded, Severe Splash	LDN-S 	Dual Primary Lips w/ Metal Band	Oil Seal — Flooded, Severe Splash
LDE-N 	Dual Primary Lips w/ Excluder Lip	Oil Seal — Flooded, Severe Splash	LDE-S 	Dual Primary Lips w/ Excluder Lip w/ Metal Band	Oil Seal — Flooded, Severe Splash
LGN-N 	Primary Lip Energized with Garter Spring	0.020" > TIR > 0.005"	LGN-S 	Primary Lip Energized with Garter Spring w/ Metal Band	0.020" > TIR > 0.005"

See a more detailed product offering for FlexiLip Seals on Page 8-8.









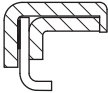

FlexiLip Seals Part Number Example

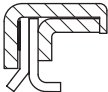
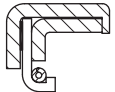
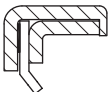
0 5 0 2 **LF** **N** 2 5 0 0 0 5 0 0 2 5 0 **N** **N**

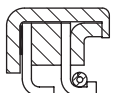
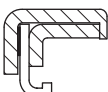
01/15/06

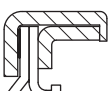

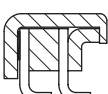
Table 4-8. FlexiCase Product Profiles

Profile	Features	Recommended Applications	Profile	Features	Recommended Applications
CFN 	Formed Primary Lip	General purpose rotary shaft seal.	CDE 	Dual Primary Lips w/ Excluder Lip	Redundant sealing for aircraft or other low leakage systems. Keeps water & dirt out.
CFE 	Formed Primary Lip w/ Excluder Lip	Ideal to keep oil in and water & dirt out.	CGN 	Primary Lip Energized with Garter Spring	Use when shaft runout is 0.010" to 0.020" or abrasive media.
CMN 	Machined Primary Lip	General purpose rotary shaft seal w/ low breakaway torque.	CGE 	Primary Lip Energized with Garter Spring w/ Excluder Lip	Use when shaft runout is 0.010" to 0.020" or abrasive media. Keeps water & dirt out.
CME 	Machined Primary Lip w/ Excluder Lip	Ideal to keep oil in and water & dirt out. Low Breakaway torque.	CJN 	Dual Lip Seal w/ Primary Lip Energized with Garter Spring	Use when redundant sealing is needed & shaft runout is 0.010" to 0.020" or abrasive media.
CEN 	Elf-Toe Primary Lip	General purpose rotary shaft seal where shaft runout is 0.005" to 0.010" or abrasive media.	CJE 	Dual Lip Seal w/ Primary Lip Energized with Garter Spring w/ Excluder Lip	Use when redundant sealing is needed & shaft runout is 0.010" to 0.020" or abrasive media. Keeps water & dirt out.
CEE 	Elf-Toe Primary Lip w/ Excluder Lip	Ideal to keep oil in and water & dirt out where shaft runout is 0.005" to 0.010" or abrasive media.	CHN 	High Pressure Dual-Lip Seal with Metal Backup Washer	Redundant seal for high pressure aircraft or other low leakage systems.
CDN 	Dual Primary Lips	Redundant sealing for aircraft or other low leakage systems.	CHE 	High Pressure Dual-Lip Seal with Metal Backup Washer w/ Excluder Lip	Redundant seal for high pressure aircraft or other low leakage systems. Keeps water & dirt out.



See a more detailed product offering for FlexiCase Seals on **Page 9-8**.

FlexiCase Seals Part Number Example

0 5 0 2 **CF N** 2 5 0 0 0 8 7 5 2 5 0 N S Z

01/15/06



