

Introduction

Catalog EPS 5370/USA

Parker Hannifin is the industry leader for sealing system solutions for the fluid power industry.



Rod Seals

Rod Seals, which guard against external leakage, are one of the most vital components of the sealing system. In recognition of their critical nature, Parker is pleased to offer the most complete range of materials and profiles in the industry. Our advanced plastic, rubber and PTFE material development delivers the highest performance in a wide variety of rod seal applications. Cutting edge technologies include multiple sealing lip systems, shock-load resistance, low friction and ultra-dry capability.

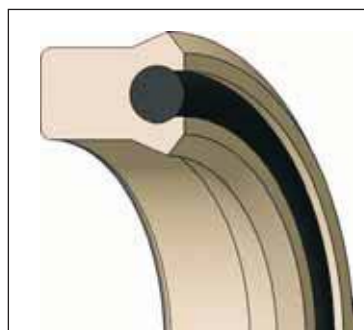

Symmetrical Seals

With thousands of available size and material combinations, Parker symmetrical profiles are designed to act as either rod or piston seals, allowing one part number to function in two applications. Often copied but never equaled, the PolyPak™ for hydraulic applications and the 8400 u-cup for pneumatic applications have revolutionized the fluid power industry and become trusted standards. Symmetrical u-cups and squeeze seals are available in a variety of lip shapes and materials.

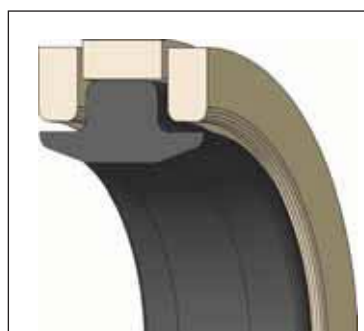

Piston Seals

Our diverse product line of piston seal profiles suits a broad range of hydraulic and pneumatic applications. Whatever the need, from low pneumatic pressures to extreme hydraulic shock loading, Parker has the solution. Profiles are available to meet the demands of uni-directional and bi-directional pressure, low friction, easy installation, port passing, and zero-drift scenarios.

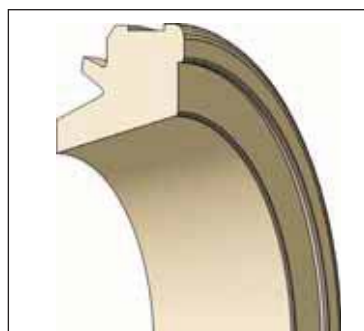

Wipers

Just as rod seals are designed to keep fluid in, Parker wipers perform to keep contamination out. Wipers work in conjunction with rod seals to form the first line of defense in protecting a system and keeping it free from dirt, mud, water, and other contaminants. Incorporating the latest technology in aggressive wiping lips and OD exclusion, Parker has solutions in press-in, snap-in, and double lip profiles.

09/01/07

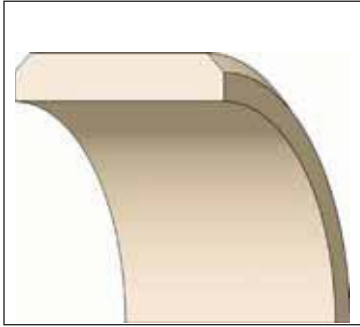

Wear Rings and Bearings

Parker offers a complete line of wear rings and bearing products to fit any application. The product offering meets the full spectrum of needs, from heavy duty hydraulic cylinders operating under the highest temperatures and pressures to pneumatic applications requiring low friction, long life and self-lubrication. No matter what the application demands, Parker's diverse bearing product line ensures that performance requirements are met with maximized value.



Back-up Rings



















































Parker back-up rings offer simple solutions to safely increase system pressure or solve an existing seal extrusion problem. Standard profiles are available in a variety of materials to complement virtually any Parker rod or piston profile.



O-rings & Head Seals





























Parker is pleased to offer the material advantages of the Resilon™ family of urethanes in standard and custom o-ring sizes. With high temperature Resilon o-rings, the need for back-ups can be eliminated, simplifying installation and reducing damage due to spiral failure. Static head seals are ideal for replacing o-rings and back-ups in hydraulic cylinder heads, fool-proofing installation and eliminating failures due to back-up pinching and blow-out.

Rod Seals (See Section 5)













Profile	Description	Application (Duty)				Page
		Hydraulic			Pneumatic	
		Light	Medium	Heavy		
BD	 Premium non-symmetrical o-ring energized rod seal with a knife trimmed primary lip and molded secondary lip. Standard materials are 4300, 4700, 5065. Available with positively actuated back-up.					5-5
BT	 Premium non-symmetrical u-cup rod seal with a knife trimmed primary lip and molded secondary lip. Standard material is 4300 family.					5-7
BS	 Non-symmetrical u-cup rod seal with knife trimmed primary lip and molded secondary lip. Standard materials are 4300 family, 4700, 5065.					5-9
B3	 Non-symmetrical u-cup with knife trimmed lip. Standard materials include 4300, 4700, 5065.					5-11
UR	 Standard non-symmetrical u-cup with trimmed lip. Standard material is 4615.					5-13
E5	 Non-symmetrical low friction rounded lip pneumatic rod seal. Standard materials include 4274, 4180, 4208, 5065.					5-21
TR	 Bi-directional rod "T-seal" available in no back-up, single back-up, and two back-up groove sizes. Standard energizer materials include 4111, 4274, 4205, 4259. Back-ups available in PTFE, Nylon, PEEK.					5-24
ON	 Bi-directional, rubber energized PTFE rod cap seal. Full range of energizer and PTFE materials available.					5-28
CR	 Bi-directional, low profile, rubber energized PTFE cap rod seal designed to fit standard o-ring glands. Full range of energizer and PTFE materials available.					5-32
OC	 Standard bi-directional rubber energized PTFE rectangular cap rod seal. Full range of energizer and PTFE materials available.					5-39
BR	 Premium knife trimmed buffer or secondary seal designed to work with a primary rod seal for heavy duty or zero-leak systems. Standard material is 4300.					5-45
OD	 Uni-directional rubber energized PTFE rod seal, typically used as a buffer or secondary rod seal. Full range of energizer and PTFE materials available.					5-48
V6	 Pneumatic cushion or check valve rod seal used to cushion the piston using internal pressure. Standard materials include 4622, 4180, 4181, 4208.					5-54
OR	 Bi-directional rubber energized PTFE rod seal used in rotary or oscillating applications. Full range of energizer and PTFE materials available.					5-57

09/01/07

Symmetrical Seals for Rod or Piston Applications (See Section 6)













































Profile	Description	Application (Duty)				Page
		Hydraulic			Pneumatic	
		Light	Medium	Heavy		
SPP	 Standard PolyPak. A square shaped symmetrical squeeze seal with a knife trimmed scraper lip. Standard materials include 4615, 4622, 4651, 4263, 4207, 4266.					6-6
DPP	 Deep PolyPak. A rectangular shaped symmetrical squeeze seal with a knife trimmed scraper lip. Standard materials include 4615, 4622, 4651, 4263, 4207, 4266.					6-8
BPP	 Type B PolyPak. A rectangular shaped symmetrical squeeze seal with a knife trimmed beveled lip. Standard materials include 4615, 4622, 4651, 4263, 4207, 4266.					6-10
SL	 A dual lip seal created by the combination of a standard PolyPak square shell and a rubber lip seal/energizer. Standard materials are a 4615 shell and 4180 lip seal/energizer. Also known as SCL-Pak.					6-39
US	 Standard symmetrical u-cup with trimmed beveled lips. Standard material is 4615.					6-42
8400 8500	 Symmetrical rubber u-cups used primarily in pneumatic applications. 8400 series feature knife trimmed with a beveled lip. 8500 series feature a scraper lip. Standard materials include 4180, 4274, 4208.					6-49
AN 6226	 Industry standard symmetrical u-cups per the old Army Navy (AN) specification. Standard material is 4295.					6-55
SPI- RAL VEE	 Spiral v-packing rings typically sold in sets, also known as chevron packing. Made from a wide range of materials, v-packing may be cut to size, machined, or net molded. Most dynamic v-packing has been replaced with PolyPak seals or u-cups.					6-59

Piston Seals (See Section 7)











































BP	 Premium bi-directional rubber energized urethane piston cap seal. Standard material is 4304.					7-5
PSP	 Standard bi-directional rubber energized urethane piston cap seal. Standard materials include 4300, 4622.					7-8
CC	 ChemCast is a heavy duty bi-directional rubber energized hard plastic, step-cut piston cap seal.					7-11
OK	 Bi-directional rubber energized nylon step-cut piston cap seal.					7-13
PIP	 Bi-directional piston seal created by the combination of a Pressure Inverting Pedestal (PIP) back-up ring and Type B PolyPak. Standard material is a 4615 PolyPak with a 4617 PIP ring.					7-15

09/01/07



















Piston Seals (See Section 7)

Profile	Description	Application (Duty)				Page
		Hydraulic			Pneumatic	
		Light	Medium	Heavy		
B7	 Premium non-symmetrical u-cup with knife trimmed lip piston seal. Standard materials include 4300, 4700, 5065.					7-19
UP	 Standard non-symmetrical u-cup with trimmed beveled lip piston seal. Standard material is 4615.					7-23
E4	 Non-symmetrical low friction rounded lip pneumatic piston seal. Standard materials include 4274, 4180, 4208, 5065.					7-26
BMP	 Low friction bumper and round lip seal profile for use in pneumatic applications. Standard materials include 4274 and 4208.					7-29
TP	 Bi-directional piston "T-seal" available in no back-up, single back-up, and two back-up grooves. Standard energizer materials include 4111, 4274, 4205, 4259. Back-ups available in PTFE, Nylon, PEEK.					7-31
S5	 Economical medium duty bi-directional o-ring energized PTFE piston seal. Standard material is 15% fiberglass-filled PTFE with nitrile energizer. Split option available.					7-35
R5	 Medium to heavy duty bi-directional lathe cut energized PTFE piston seal. Full range of energizer and PTFE materials available. Split option available.					7-39
CT	 Four piece capped "T-seal" piston seal made from molded rubber energizer, PTFE cap, and Nylatron back-ups.					7-43
CQ	 Bi-directional three piece lathe cut energized PTFE cap piston seal with an integrated quad seal for zero drift. Also available with dual o-ring energizer.					7-48
OE	 Bi-directional, rubber energized PTFE piston cap seal. Full range of energizer and PTFE materials available.					7-53
CP	 Bi-directional low profile, rubber energized PTFE cap piston seal designed to fit standard o-ring glands. Full range of energizer and PTFE materials available.					7-62
OA	 Standard bi-directional rubber energized PTFE rectangular cap piston seal. Full range of energizer and PTFE materials available.					7-68
OQ	 Bi-directional rubber energized PTFE piston seal used in rotary or oscillating applications. Full range of energizer and PTFE materials available.					7-74

















09/01/07

Wipers (See Section 8)						
Profile	Description	Application (Duty)				Page
		Hydraulic			Pneumatic	
		Light	Medium	Heavy		
YD		Premium snap-in wiper with OD exclusion lip and a knife trimmed wiping lip. Standard material is 4300.				8-5
SHD		Slotted heel snap-in wiper for pneumatics and light to medium duty hydraulics. Standard materials are 4615, 5065, 4263, 4208, 4207.				8-6
SHX		Slotted heel snap-in wiper with OD exclusion feature. Designed to upgrade SHD wipers without changing the groove. Standard materials are 4615, 5065.				8-7
SH959		An industry standard slotted heel Army Navy (AN) wiper designed to fit MS-28776 (MS-33675) grooves. Standard materials are 4615, 5065, 4263, 4208, 4207.				8-11
SX959		An industry standard slotted heel Army Navy (AN) wiper with an OD exclusion feature designed to fit MS-28776 (MS-33675) grooves. Designed to upgrade SH959 wipers without changing the groove. Standard materials are 4615, 5065, 4263, 4208, 4207.				8-12
AH		Double-lip, press in place, metal canned wiper with knife trimmed sealing lip for heavy duty hydraulics. Standard materials are 4300, 4700, 4615.				8-15
J		Standard single-lip, press in place, metal canned wiper with a knife trimmed lip for medium and heavy duty hydraulics. Standard materials are 4300, 4700, 4615.				8-17
AY		Premium snap-in place double-lip wiper for hydraulic applications. Standard materials are 4300, 4301, 4700.				8-19
H / 8600		Standard snap-in place double-lip wiper. Standard materials for H wiper are 4615, 5065. Standard material for 8600 wiper is 4181.				8-21
K		Light load snap-in wiper with double-lip designed for low friction, light load applications. Standard material is 4615.				8-27
AD		Double acting, double-lip, rubber energized PTFE wiper. Full range of energizer and PTFE materials available.				8-30
SG		Metal scraper with rubber energizer for excluding abrasive contaminants.				8-36











Wear Rings / Bearings (See Section 9)

Profile	Description	Application (Duty)				Page
		Hydraulic			Pneumatic	
		Light	Medium	Heavy		
WPT 	Tight tolerance piston wear ring with chamfered corners. Standard material is 4733 WearGard™.					9-7
WRT 	Tight tolerance rod wear ring with chamfered corners. Standard material is 4733 WearGard.					9-11
WN 	Standard commercial wear ring for rod and piston applications. Standard material is 4650 MolyGard™.					9-14
PDT 	PTFE wear strip/bearing available cut to length or in bulk rolls. A variety of PTFE compounds are available.					9-18
PDW 	Precision cut wear ring/bearing machined from PTFE billet material. Rod and piston chamfer may apply.					9-27

Back-ups (See Section 10)

MB 	Heavy cross-section modular back-up for PolyPak seals. Standard materials are 4617, 4652.					10-4
8700 	Light cross-section back-up for PolyPak and u-cup seals. Standard materials are 4651, 4729.					10-10
5100 	Back-up rings designed for o-ring grooves. Standard materials are 4651, 4729.					10-13
PAB 	Positively actuated back-up ring incorporated into common seal profiles to extend a seal's pressure range. Sold as an assembly with the seal.					10-21
PDB 	Anti-extrusion PTFE ring offered in solid and split configurations. Full PTFE material range applies.					10-22





Urethane O-Rings & Head Seals (See Section 11)

568 	High performance urethane o-ring made from the Resilon™ family of high temperature, low compression set urethanes.					11-2
HS 	Static head seals designed to replace o-rings and back-up in static applications. Standard material is 4700.					11-15

General Application Guidelines

Parker's selection of products is the broadest offering in the industry for hydraulic and pneumatic sealing systems. Table 1-1 provides "General Application Guidelines" to help define possible differences between light, medium and heavy duty applications. The product profile charts beginning on page 1-4 show corresponding application duty recommendations for each profile.

Table 1-1. General application guidelines.

Application Parameter	Hydraulic			Pneumatic	
	 Light Duty	 Medium Duty	 Heavy Duty	 Light Duty	 Heavy Duty
Pressure Range	<1200 psi (<83 bars)	<3500 psi (<241 bars)	>3500 psi (>241 bars)	1 to 200 psi (0 to 14 bar)	Above 200 psi (Above 14 bars)
Pressure Spikes	None or low	Not to exceed twice the system pressure. Short duration such as valve shifting.	Pressure spikes that may be several times the system pressure and of a longer duration. These are often mechanically induced by forcing the rod in or out.	Because of the compressive nature of gases pressure spikes are typically not a problem.	Because of the compressive nature of gases pressure spikes are typically not a problem.
Temperature Range	0°F to 160°F (-18°C to 71°C)	-20°F to 200°F (-29°C to 93°C)	-45°F to 225°F (-43°C TO 107°C)	0°F to 72°F (-18°C to 22°)	Cryogenic to 450°F (232°C)
Contamination	Low or non existing	Moderate with cylinder in horizontal or inverted position.	Moderate to high with the cylinder upright - vertical	Low or non existing	Moderate to high with the cylinder upright - vertical
Side Loading	None to light with shorter stroke and vertical cylinder mount.	Moderate side load with cylinder mounted towards the vertical position. Medium stroke.	Longer stroke lengths. Cylinder mounted horizontal, heavy side loading.	None to light with shorter stroke and cylinder mount vertical.	Longer stroke lengths. Cylinder mounted horizontal, heavy side loading.

It is not uncommon for the requirements of a sealing system to fall into multiple duty columns. When this situation occurs you should select the majority of your components from the lesser duty range.

When selecting a wiper, focus on contamination section.

In selecting a sealing component you will evaluate the temperature, pressure and pressure spike variables of the application. With a wear ring, you will want to look at the temperature and side loading section. This does not preclude the need to consider such things as fluid being sealed and stroke speed.

The Parker Advantage

Parker is the world's leading diversified manufacturer of motion and control technologies and systems, providing precision-engineered solutions for a wide variety of commercial, mobile, industrial and aerospace markets. The Engineered Polymer Systems (EPS) Division of Parker Seal Group, has over 40 years experience designing and manufacturing elastomeric, polymeric and plastic seals, materials, and sealing systems for dynamic applications. Working with Parker EPS Division gives you access to all of Parker's Seal Group in North America, Europe, and Asia.

Worldwide Manufacturing

Parker Seal Group and EPS Division's manufacturing facilities for dynamic seals include:

North America:

EPS Division Salt Lake City

Division Headquarters
Plastic & Rubber Operations
2220 South 3600 West
Salt Lake City, UT 84119

EPS Division Nacogdoches

Clipper Operations
Oilfield Rubber Operations
Expansion Joint Operations
403 Industrial Blvd.
Nacogdoches, TX 75964
Ph: (800) 233-3900

EPS Division PTFE Operations:

EPS Division, Elgin Operations
2565 Northwest Parkway
Elgin, IL 60124
Ph: (847) 783-4300

EPS Division, Marion Operations
3967 Buffalo Street
Marion, NY 14505
Ph: (315) 926-4211

EPS Division, Baja Operations
Baja, Mexico
Ph: (619) 671-3257



EPS Division Salt Lake City Operations



EPS Division Chicago (Elgin)



EPS Division Nacogdoches



EPS Division Marion



EPS Division Baja

09/01/07

Europe:**Packing Operations:**

Prädifa, Stuttgart, Germany
Ph: (+49) 7142 351-0

PTFE Operations:

Polar Seals ApS, Espergaerde, Denmark
Ph: (+45) 49 121700

Advanced Products NV, Boom, Belgium
Ph: (+32) 3 880 81 50

Sadska, Czech Republic
Ph: (+420) 325 555 111

Asia:

Parker Hannifin Motion & Control Co., Ltd.
Shanghai, China
Ph: (+86) 21 28995181

*Bietigheim**Denmark**Belgium**Czech Republic*

Manufacturing Excellence

Parker's manufacturing capabilities accommodate a wide range of dynamic sealing needs, providing the following value benefits to our customers:

- All manufacturing operations offer state of the art processes and procedures that enable Parker to provide world class products, in both standard and custom profiles.
- Specialized cellular manufacturing and lean concepts enable Parker to handle both low and high volume runs with equal efficiency.
- Breadth of tooling capability produces diameters as small as 1/16 inch and as large as 9 feet without splicing.
- Custom high speed trim machines ensure a sharp sealing edge for the ultimate seal performance wherever possible.

Rubber Operations

With over 400 unique rubber compounds, Parker has the largest selection of materials available in the industry. Our material offering includes custom blends of nitrile, ethylene propylene and fluorocarbons, among others. If an application demands unique material specifications, our in-house chemists have the expertise and capability to assist in specifying and validating optimal materials to meet system requirements. State of the art rubber molding processes such as compression, transfer, injection and injection-compression are used to manufacture the highest quality products.



Rubber Injection Press

Plastic Operations

Our plastics material offering includes such seal industry standards as Molythane™, PolyMyte™, WearGard™, MolyGard™, and many more. Parker's

Resilon™ family offers the highest temperature performance of any urethane in the industry. Our commitment to quality and research and development remains a top priority to ensure leading edge status in new material development. With in-house processing, from manufacturing the plastic pellet to molding the finished product, Parker maintains strict controls which ensure the delivery of quality products from quality materials — start to finish.



Plastic Manufacturing

PTFE Operations

Parker's PTFE operations manufacture high quality machined seals from ¼ inch to 72 inches in diameter, utilizing virgin and proprietary blends of filled PTFE. A wide variety of PTFE fluid power seals are manufactured on state of the art CNC equipment with live tooling and multi-axis capabilities. Automated processing allows the efficient handling of both low and high volume runs. PTFE production at Parker is entirely an internal system, from material blending and molding to sintering and CNC machining. Our commitment to quality and service is supported by investment in advanced technology, test and inspection methods.



PTFE Manufacturing

Applications Engineering

Our team of application engineers can help you find the most reliable, cost-effective sealing solution for your product. These engineers are experts, combining decades of sealing experience in real-world applications with a full complement of technology-driven tools to produce the answers you need.

FEA

Utilizing advanced non-linear Finite Element Analysis (FEA) software our engineers can perform extremely accurate virtual simulations of material performance based on actual physical test data. These simulations eliminate the need for multiple iterations of costly prototype tooling, and dramatically reduce development lead times. They also ensure first-time selection of the best material and geometry for your application.

Mechanical Test Lab

Parker's mechanical test lab is an important asset for validating new designs and qualifying seals to customers' performance specifications. Our sophisticated mechanical testing lab utilizes several breakthrough technologies, enabling engineers to validate seals and sealing systems for hydraulic, pneumatic and rotary systems. All product testing is carried out in accordance with ASTM and SAE specifications as well as customer-specific requirements.

Hydraulic testing capabilities include pressures up to 10,000 psi with environmental chambers to control temperatures from -40 to 300 °F. Tests can be performed on assembled cylinders or can be configured on test stands which isolate performance of rod seals, piston seals and wipers for troubleshooting and fine tuning. For heavy contamination situations, our dust chamber can be used to simulate the most rigorous operating environments, putting seals to the ultimate test.

Pneumatic testing is also environmentally controlled to simulate a variety of operating conditions. Endurance and life cycle tests can be performed on applications of all speeds and pressures, from automation and assembly cylinders to high speed pneumatic hand tools.

Rotary testing capabilities range from low speed, high pressure hydraulic swivels to high speed gear box and bearing applications in extreme operating conditions, validating seal performance across a wide range of industries.

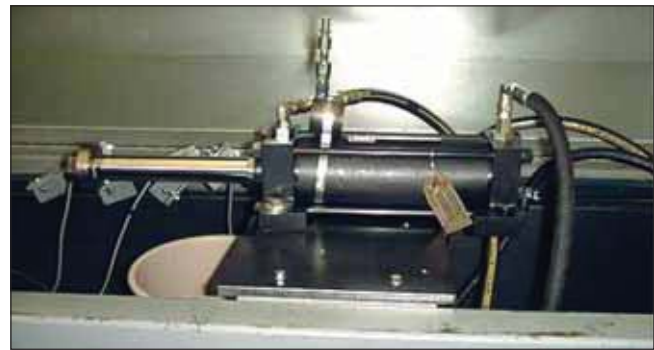

Low pressure life cycle testing



Pneumatic cylinder testing



High pressure hydraulic leakage testing



Rotary hydraulic testing

09/01/07

Premier Customer Support

Worldwide and local support is just a phone call away. Our local Parker sales representatives provide a single point of contact for local sealing support. Our established worldwide network of over 300 distributor and service center locations combined with factory direct representatives, including global sales and engineering, ensures access to quality products and engineering services anytime, anywhere.

Customer service is a key component of the Parker package. Electronic ordering systems such as EDI and PHconnect make placing and tracking orders easy. Our knowledgeable customer service representatives are only a phone call away at 801 972 3000.



SmartScope™ inspection

Quality Commitment

Parker is committed to consistently delivering excellence in quality and service through continuous improvement of our people, products and systems. Our manufacturing facilities are registered to either AS9100, ISO/9000, or TS16949 standards.

Our commitment to quality and service is supported by our investment in advanced test and inspection methods and equipment. Parker constantly strives to improve customer satisfaction and product quality through the implementation of:

- Six Sigma
- Lean manufacturing
- Kaizen events
- TQM
- Advanced product quality planning (APQP)
- Feasibility studies



CMM: Coordinate measuring tool inspection

Parker is consistently willing to explore new ideas with the companies and individuals we serve. Customers come to Parker for different reasons, but our role is always the same . . . working to use our expertise and help our customers engineer their success.